

FLENDER ELPEX-S® couplings

Types ESD, ESDR, ESN, ESNR,
ESNW, ESDW, EST

Operating instructions
BA 3302 en 06/2012



FLENDER couplings

SIEMENS



FLENDER ELPEX-S[®] couplings

Types ESD, ESDR, ESN, ESNR,
ESNW, ESDW, EST

Operating instructions

Translation of the original operating instructions

Technical data **1**

Notes **2**

Fitting **3**

**Start-up
and operation** **4**

**Faults, causes
and remedy** **5**

**Maintenance
and repair** **6**

Stocking spare parts **7**

Declarations **8**

Notes and symbols in these operating instructions

Note: The term "operating instructions" will in the following also be shortened to "instructions" or "manual".

Legal notes

Warning-note concept

This manual comprises notes which must be observed for your personal safety and for preventing material damage. Notes for your personal safety are marked with a warning triangle or an "Ex" symbol (when applying Directive 94/9/EC), those only for preventing material damage with a "STOP" sign.



WARNING! Imminent explosion!

The notes indicated by this symbol are given to prevent **explosion damage**.
Disregarding these notes may result in serious injury or death.



WARNING! Imminent personal injury!

The notes indicated by this symbol are given to prevent **personal injury**.
Disregarding these notes may result in serious injury or death.



WARNING! Imminent damage to the product!

The notes indicated by this symbol are given to prevent **damage to the product**.
Disregarding these notes may result in material damage.



NOTE!

The notes indicated by this symbol must be treated as general **operating information**.
Disregarding these notes may result in undesirable results or conditions.



WARNING! Hot surfaces!

The notes indicated by this symbol are made to prevent **risk of burns due to hot surfaces**
and must always be observed.
Disregarding these notes may result in light or serious injury.

Where there is more than one hazard, the warning note for whichever hazard is the most serious is always used. If in a warning note a warning triangle is used to warn of possible personal injury, a warning of material damage may be added to the same warning note.

Qualified personnel

The product or system to which these instructions relate may be handled only by persons qualified for the work concerned and in accordance with the instructions relating to the work concerned, particularly the safety and warning notes contained in those instructions. Qualified personnel must be specially trained and have the experience necessary to recognise risks associated with these products or systems and to avoid possible hazards.

Intended use of Siemens products

Observe also the following:



Siemens products must be used only for the applications provided for in the catalogue and the relevant technical documentation. If products and components of other makes are used, they must be recommended or approved by Siemens. The faultfree, safe operation of the products calls for proper transport, proper storage, erection, assembly, installation, start-up, operation and maintenance. The permissible ambient conditions must be adhered to. Notes in the relevant documentations must be observed.

Trademarks

All designations indicated with the registered industrial property mark ® are registered trademarks of Siemens AG. Other designations used in these instructions may be trademarks the use of which by third parties for their own purposes may infringe holders' rights.

Exclusion of liability

We have checked the content of the instructions for compliance with the hard- and software described. Nevertheless, variances may occur, and so we can offer no warranty for complete agreement. The information given in these instructions is regularly checked, and any necessary corrections are included in subsequent editions.

Note on the EC Machinery Directive 2006/42/EC

Siemens couplings in the "FLENDER couplings" product range must be treated as "components" in the sense of the EC Machinery Directive 2006/42/EC.

Therefore, Siemens needs not issue a declaration of incorporation.

Information on safe fitting, safe startup and safe operation can be found in this instructions manual; in addition the "warning-note concept" therein must be observed.

Contents

1.	Technical data	6
1.1	Rubber disk elements	6
1.2	Geometric data of type ESD	7
1.3	Geometric data of type ESDR	8
1.4	Geometric data of type ESN	9
1.5	Geometric data of type ESNR	10
1.6	Geometric data of types ESNW and ESDW	11
1.7	Geometric data of type EST	12
2.	Notes	13
2.1	Safety instructions and general notes	13
2.2	Marking of the coupling parts for use in potentially explosive zones	14
2.3	Operating conditions in potentially explosive areas	14
3.	Fitting	16
3.1	Machining the finished bore	16
3.2	Machining the parallel keyway	16
3.3	Axial securing	17
3.4	Balancing after machining the finished bore	17
3.5	Fitting the coupling parts 1 and 2	18
3.6	Fitting the coupling parts 5 with TAPER clamping bush on type EST	18
3.7	Fitting the coupling	19
3.8	Possible misalignments	19
3.8.1	Axial misalignment	19
3.8.2	Angular misalignment	19
3.8.3	Radial misalignment	19
3.9	Alignment	20
3.10	Shaft-misalignment values during operation	21
3.11	Bolt-tightening torques	21
3.11.1	Bolt-tightening torques for bolting the outer flange (3) to the motor flywheel	22
3.11.2	Bolt-tightening torques for bolting the outer flange (3) to the flanged ring (101) of types ESNW, ESDW	22
3.11.3	Bolt-tightening torques for bolting the hub (2) to the rubber disk element (5; 6) and the hub (1) to the flanged ring (101)	22
3.11.4	TAPER clamping bushes	22
4.	Start-up and operation	23
5.	Faults, causes and remedy	23
5.1	Possible cause of the fault	23
5.2	Incorrect use	23
5.2.1	Frequent faults when selecting the coupling and/or coupling size	24
5.2.2	Frequent faults when fitting the coupling	24
5.2.3	Frequent faults in maintenance	25
6.	Maintenance and repair	25
6.1	General	25
6.2	Replacement of wearing parts	25
6.3	Demounting the coupling parts 1 and 2 in case of shaft-hub connection with parallel key	25
6.4	Demounting the coupling parts 5 with TAPER clamping bush on type EST	26
7.	Stocking spare parts	26
7.1	Spare parts	26
8.	Declarations	28
8.1	EC declaration of conformity	28

1. Technical data

The instructions describe the coupling in horizontal mounting position with shaft-to-hub connection by cylindrical or conical bore with parallel key or with TAPER clampimng bush and/or a bolted flange. If other shaft-hub connections, such as shrink fit or splines to standard "DIN 5480", are to be used, or if the coupling must be used in a vertical or inclined position, Siemens must be consulted.

The couplings described in this manual of the types ESD, ESDR, ESN, ESNR, ESNW and ESDW may also be used in potentially explosible areas. The couplings must have a CE marking (for marking, see item 2.2).



Couplings which do not have a CE marking must not be used in potentially explosive areas.

The type EST coupling is not approved for use in potentially explosive areas.

If a dimensioned drawing has been made out for the coupling, the data in this drawing must be given priority. The dimensioned drawing including any other documents should be made available to the user of the system.

Part numbers and part designations of the spare-parts drawing and spare-parts list can be found in section 7, "Spare-parts stockage" or on the dimensioned drawing.

1.1 Rubber disk elements

- Rubber disk elements may be stored for up to 5 years.
- Rubber disk elements must be protected against direct sunlight, artificial light with a high ultraviolet content and extreme temperatures.
- Rubber disk elements must not come into contact with aggressive media.
- Rubber disk elements must not be heated up to impermissible temperatures during fitting work (see table 1).

Table 1: ELPEX-S rubber disk elements

Material	Hardness	Mark	Temperature range
Natural/synthetic rubber	50 ° ... 55 ° Shore A	WN	- 40 °C to + 80 °C
Natural/synthetic rubber	60 ° ... 65 ° Shore A	NN	- 40 °C to + 80 °C
Natural/synthetic rubber	70 ° ... 75 ° Shore A	SN	- 40 °C to + 80 °C
Silicon rubber	55 ° ... 65 ° Shore A	NX	- 40 °C to + 120 °C



Rubber disk elements made of silicon-rubber mix (rubber version NX) are not approved for use in potentially explosive areas.



Observe assignement of temperature classes to ambient temperatures to table 8, or for dust table 9.

1.2 Geometric data of type ESD

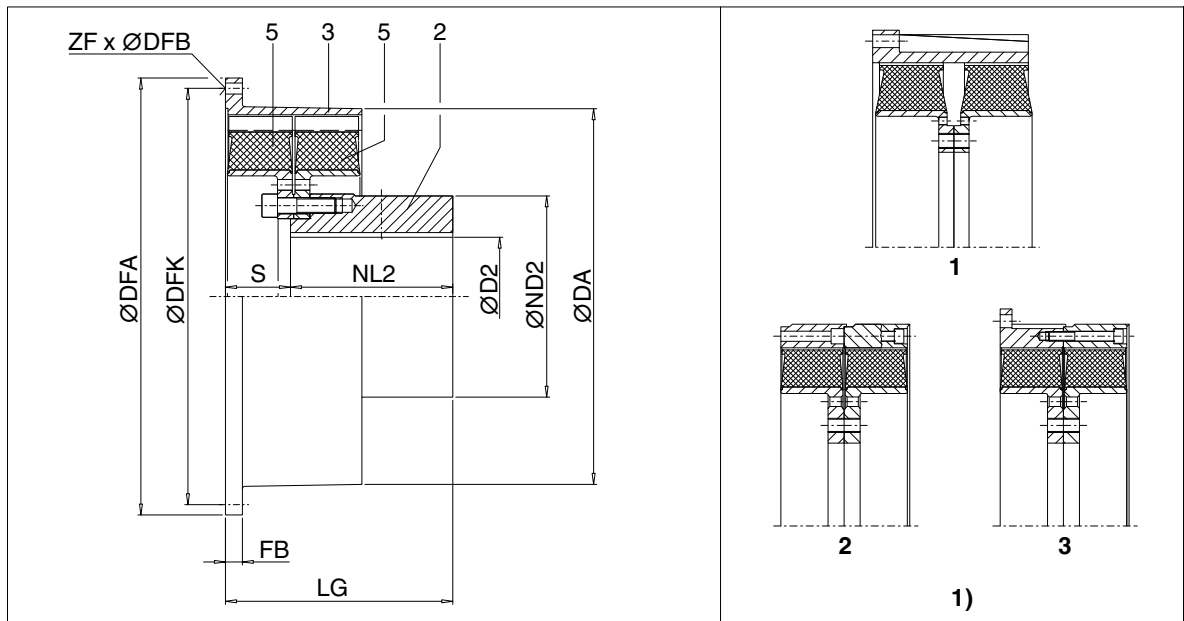

Fig. 1: Type ESD

1) Flange versions

Table 2: Geometric data and weights of type ESD

Size	Flange version	D2 1) mm	DA mm	ND2 mm	NL2 mm	S 2) mm	LG 2) mm	Flange connection SAE J620d					Weight 3) kg	
								Size	DFA g7 mm	DFK mm	FB mm	ZF mm		DFB mm
520	1	165	525	250	174	81	255	18	571.5	542.9	25	12	17	85
								21	673.1	641.4	18	12	17	90
560	1	170	560	316	210	60	270	18	571.5	542.9	35	12	17	140
								21	673.1	641.4	35	12	17	150
580	1	200	585	310	250	100	350	21	673.1	641.4	26	12	17	170
								24	733.4	692.2	26	12	21	175
680	2 3	220	682	380	250	17	267	21	673.1	641.4	85	12	17	265
								24	733.4	692.2	20	12	21	275

1) Maximum bore with keyway to standard "DIN 6885/1".

2) Permissible deviation (see item 3.9).

3) Weights are valid for maximum bores.

1.3 Geometric data of type ESDR

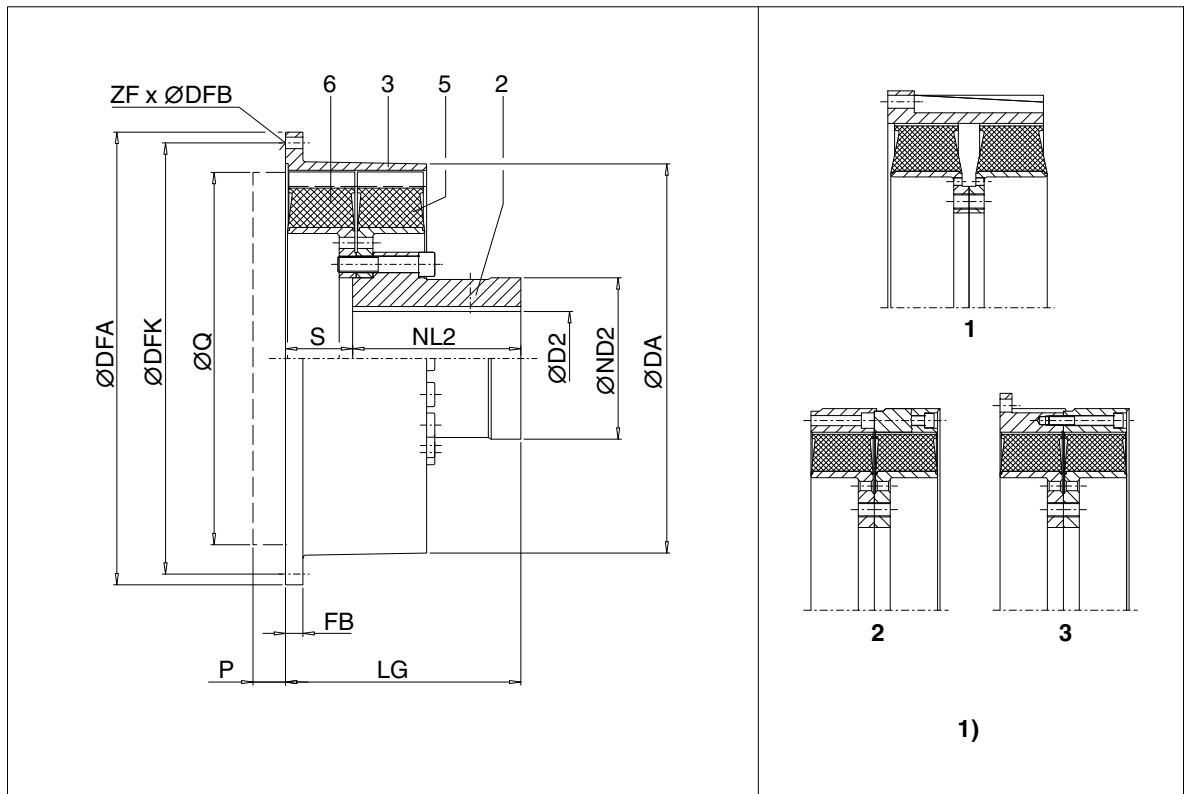

Fig. 2: Type ESDR

1) Flange versions

Table 3: Geometric data and weights of type ESDR

Size	Flange version	D2 1)	DA mm	ND2 mm	NL2 mm	P mm	Q mm	S 2) mm	LG 2) mm	Flange connection SAE J620d					Weight 3) kg	
										Size	DFA g7 mm	DFK mm	FB mm	ZF mm		DFB mm
520	1	150	525	227	226	10	498	83	309	18	571.5	542.9	25	12	17	105
										21	673.1	641.4	18	12	17	110
560	1	160	560	248	240	10	498	100	340	18	571.5	542.9	35	12	17	135
										21	673.1	641.4	35	12	17	140
580	1	160	585	240	250	10	560	100	350	21	673.1	641.4	26	12	17	145
										24	733.4	692.2	26	12	21	150
680	2 3	200	682	300	250	10	584	102	352	21	673.1	641.4	85	12	17	260
										24	733.4	692.2	20	12	21	270
770	3	260	780	390	300	10	750	200	500	-	860.0	820.0	19	32	21	540
										-	920.0	880.0	27	32	21	555
										-	995.0	950.0	27	32	21	600

1) Maximum bore with keyway to standard "DIN 6885/1".

2) Permissible deviation (see item 3.9).

3) Weights are valid for maximum bores.

1.4 Geometric data of type ESN

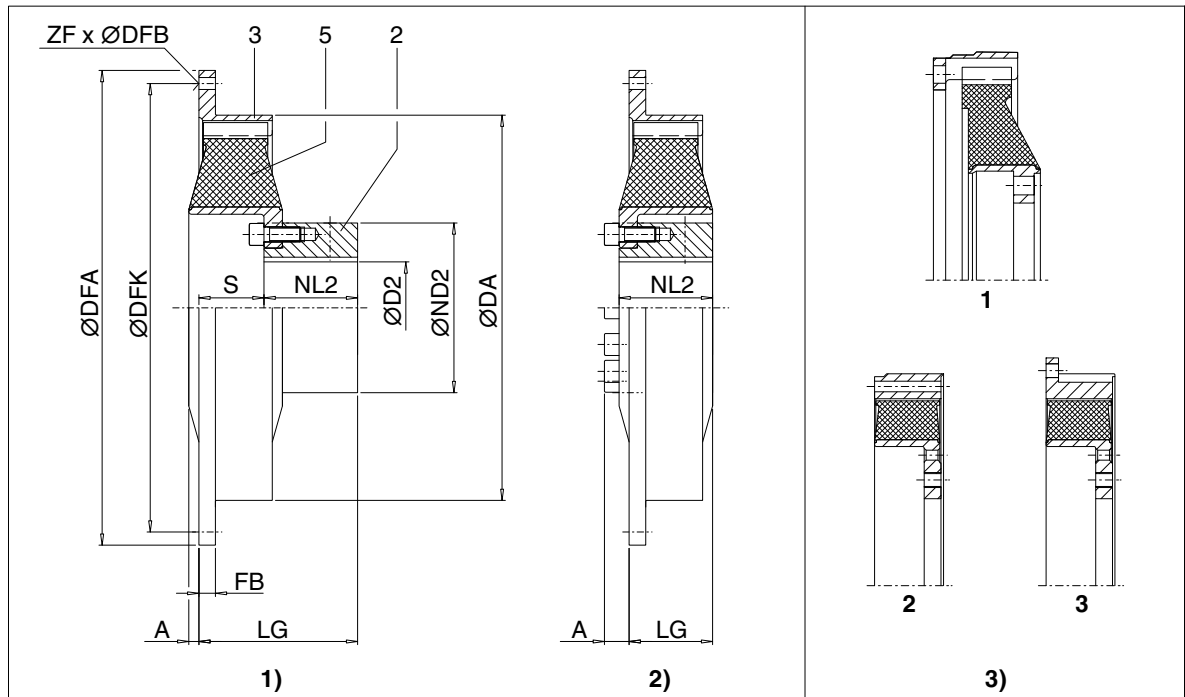

Fig. 3: Type ESN

1) long version

2) short version

3) Flange versions

Table 4: Geometric data and weights of type ESN

Size	Flange version	D2 1)	DA mm	ND2 mm	NL2 mm	2) Permissible deviation					Flange connection SAE J620d					Weight 3) kg	
						A mm	S mm	LG mm	A mm	LG mm	Size	DFA g7 mm	DFK mm	FB mm	ZF mm		DFB mm
220	1		222				49	103			6.5	215.9	200.0	8	6	8.5	5.8
	2		237	98	54	0	40	94	-	-	7.5	241.3	222.3	33	8	8.5	6.1
	3	60	222				40	94			8	263.5	244.5	8	6	10.5	6.4
	3		222				40	94			10	314.3	295.3	8	8	10.5	6.9
265	2										8	263.5	244.5	38	6	10.5	6.6
	3	65	263	118	65	3	39	104	15	74	10	314.3	295.3	10	8	10.5	6.9
	3										11.5	352.4	333.4	10	8	10.5	7.2
290	3	65	290	118	70	6	36	106	18	58	10	314.3	295.3	16	8	10.5	9.2
											11.5	352.4	333.4	16	8	10.5	10.5
320	3	80	318	140	87	8	65	152	20	91	11.5	352.4	333.4	16	8	10.5	19
											14	466.7	438.2	16	8	13	20.5
360	3	90	358	160	105	13	56	161	29	92	11.5	352.4	333.4	65	8	10.5	24.5
											14	466.7	438.2	15	8	13	27.5
420	3	100	420	185	102	10	72	174	26	92	14	466.7	438.2	18	8	13	36
											16	517.5	489.0	18	8	13	38
											18	571.5	542.9	18	6	17	40
465	3	120	465	222	125	2	39	164	33	92	14	466.7	438.2	85	8	13	56
											16	517.5	489.0	27	8	13	57
											18	571.5	542.9	18	6	17	61
520	3	165	514	250	142	0	83	225	16	159	18	571.5	542.9	18	12	17	55
											21	673.1	641.4	18	12	17	60
560	3	200	560	320	140	2.5	83	223	30	130	18	571.5	542.9	35	12	17	69
											21	673.1	641.4	35	12	17	78
580	3	200	580	316	200	0	100	300	23	215	18	571.5	542.9	104	12	17	100
											21	673.1	641.4	26	12	17	105
680	3	220	682	380	210	0	102	312	24	232	21	673.1	641.4	85	12	17	205
											24	733.4	692.2	20	12	21	215

1) Maximum bore with keyway to standard "DIN 6885/1".

2) Permissible deviation (see item 3.9).

3) Weights are valid for maximum bores.

1.5 Geometric data of type ESNR

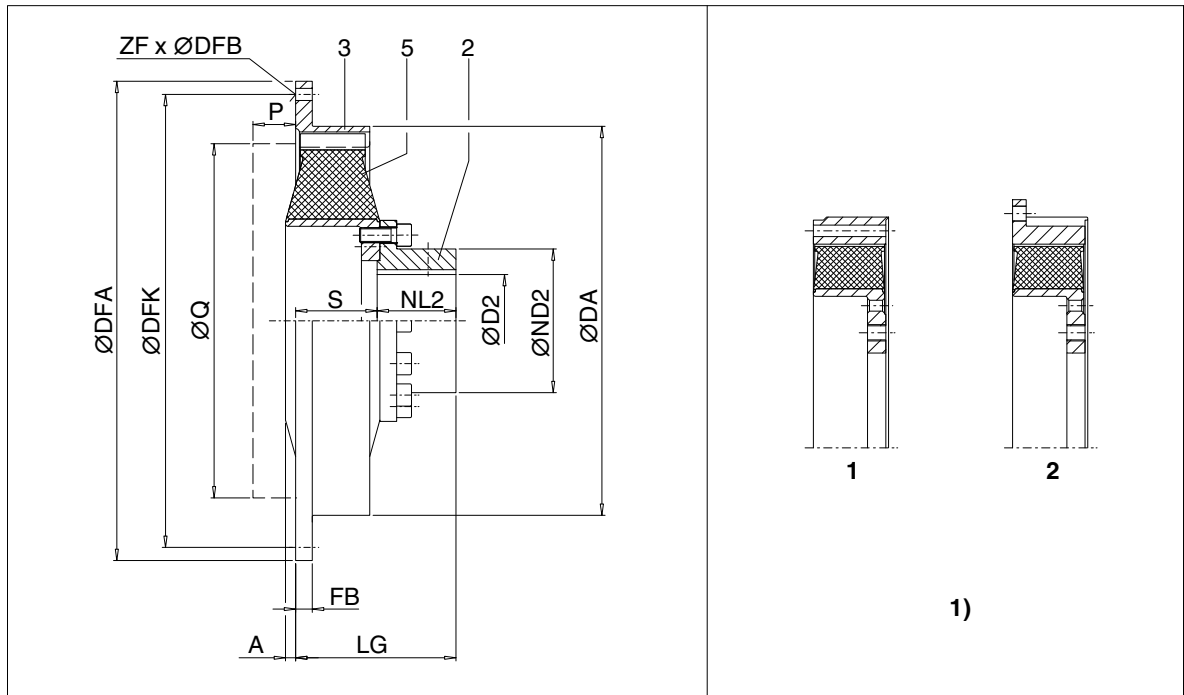

Fig. 4: Type ESNR

1) Flange versions

Table 5: Geometric data and weights of type ESNR

Size	Flange version	D2 1)	DA	ND2	NL2	P	Q	A 2)	S 2)	LG 2)	Flange connection SAE J620d					Weight 3) kg	
											Size	DFA g7	DFK	FB	ZF		DFB
		mm	mm	mm	mm	mm	mm	mm	mm	mm		mm	mm	mm	mm	mm	
265	1										8	263.5	244.5	38	6	10.5	5
	2	50	263	78	65	10	225	0	42	107	10	314.3	295.3	10	8	10.5	5.3
	2										11.5	352.4	333.4	10	8	10.5	5.6
290	2	50	290	78	65	15	276	2	59	124	10	314.3	295.3	16	8	10.5	8.1
											11.5	352.4	333.4	16	8	10.5	8.4
320	2	65	318	98	87	20	310	4	69	156	11.5	352.4	333.4	16	8	10.5	13.5
											14	466.7	438.2	16	8	13	16
360	1										11.5	352.4	333.4	65	8	10.5	20
	2	85	358	123	88	28	314	9	77	165	14	466.7	438.2	15	8	13	23
420	2	100	420	155	85	28	409	6	93	178	14	466.7	438.2	18	8	13	31
											16	517.5	489.0	18	8	13	32
											18	571.5	542.9	18	6	17	35
465	1										14	466.7	438.2	85	8	13	41
	2	130	465	190	119	15	409	0	88	207	16	517.5	489.0	27	8	13	42
	2										18	571.5	542.9	18	6	17	45
520	2	150	514	227	162	10	498	0	85	247	18	571.5	542.9	18	12	17	59
											21	673.1	641.4	18	12	17	64
560	2	150	560	240	180	10	498	0	99	279	18	571.5	542.9	35	12	17	75
											21	673.1	641.4	35	12	17	85
580	1										18	571.5	542.9	104	12	17	80
	2	160	580	240	200	10	498	0	102	302	21	673.1	641.4	26	12	17	84
680	1										21	673.1	641.4	85	12	17	155
	2	200	682	300	210	10	584	0	102	312	24	733.4	692.2	20	12	21	165
770	2	260	780	390	255	10	750	0	134	389	-	860.0	820.0	26	32	21	330
											-	920.0	880.0	27	32	21	350
											-	995.0	950.0	27	32	21	375

1) Maximum bore with keyway to standard "DIN 6885/1".

2) Permissible deviation (see item 3.9).

3) Weights are valid for maximum bores.

1.6 Geometric data of types ESNW and ESDW

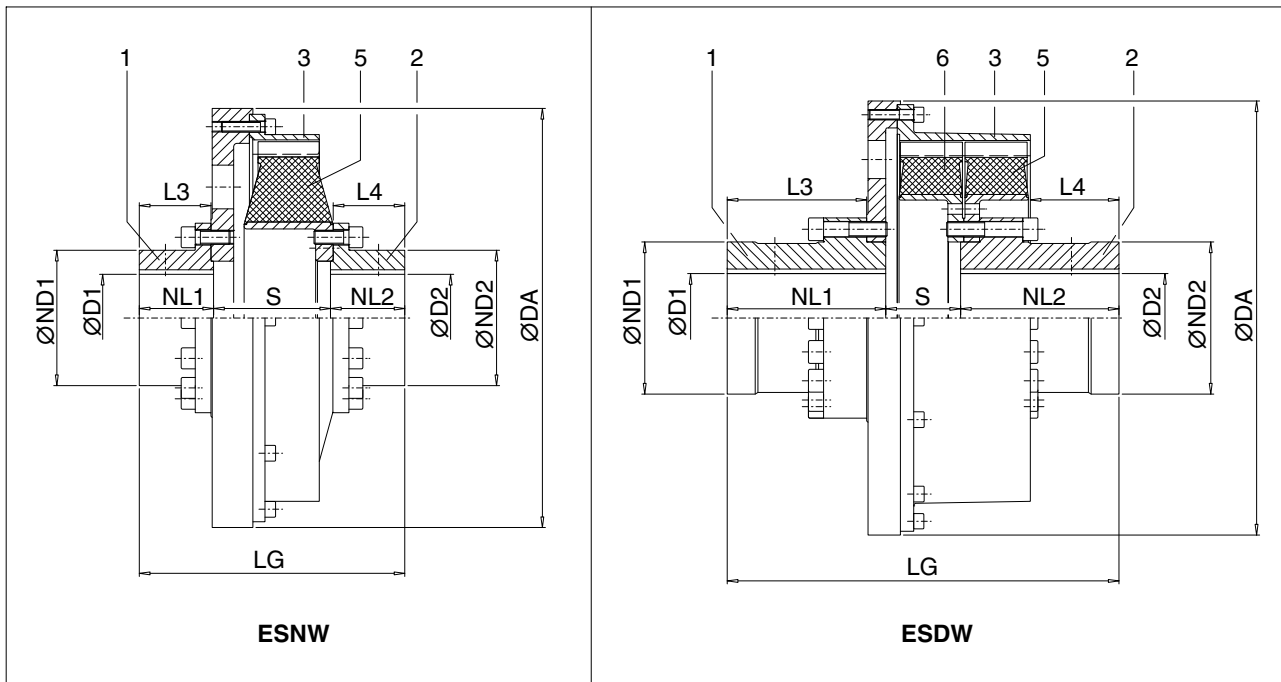

Fig. 5: Types ESNW and ESDW

Table 6: Geometric data and weights of types ESNW and ESDW

Type	Size	D1 / D2 1)	DA	ND1 ND2	NL1 NL2	L3	L4	S 2)	L 2)	Weight 3)
		mm	mm	mm	mm	mm	mm	mm	mm	kg
ESNW	265	50	275	78	65	62	66	68	198	15
ESNW	290	50	325	78	65	62	68	89	219	22
ESNW	320	65	365	98	87	84	92	100	274	32
ESNW	360	85	365	123	88	85	96	123	299	43
ESNW	420	100	480	155	85	82	94	134	304	75
ESNW	465	130	480	190	119	116	119	125	363	89
ESNW	520	150	585	227	162	159	161	123	447	155
ESNW	560	150	585	240	180	174	174	132	492	160
ESNW	580	150	685	240	200	195	198	145	545	185
ESNW	680	200	685	300	210	205	201	150	570	315
ESNW	770	260	870	390	255	250	253	180	690	500
ESDW	520	150	585	227	226	201	135	100	552	215
ESDW	560	160	585	248	240	215	133	114	594	250
ESDW	580	160	685	240	250	220	140	120	620	300
ESDW	680	200	685	300	250	218	134	125	625	440
ESDW	770	260	870	390	300	265	238	220	820	720

1) Maximum bore with keyway to standard "DIN 6885/1".

2) Permissible deviation (see item 3.9).

3) Weights are valid for maximum bores.

1.7 Geometric data of type EST

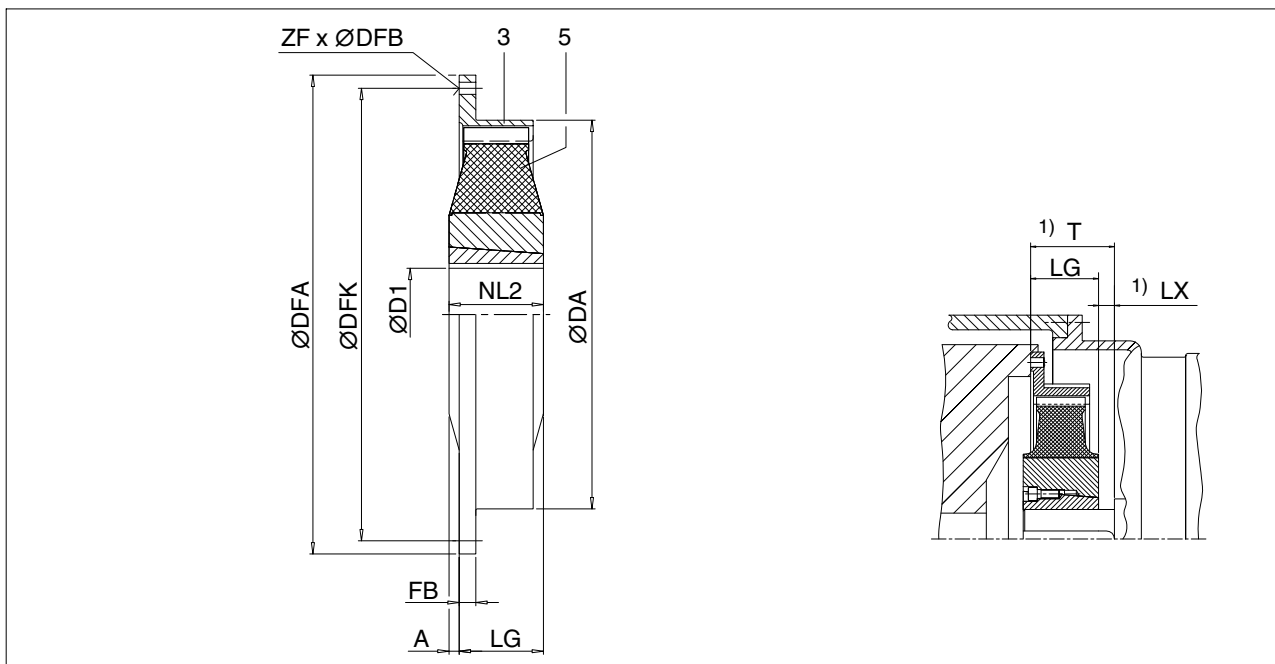

Fig. 6: Type EST

Table 7: Geometric data and weights of type EST

Size	TAPER-Spannbuchse	D1		DA	NL2	1)	1)	2)	2)	Flange connection SAE J620d						Weight ³⁾ kg
		min. mm	max. mm			A	LG	T	LX	Size	DFA g7 mm	DFK mm	FB mm	DFB mm	ZF mm	
220	2012	14	50	222	32	0	52	-	-	6.5	215.9	200	8	8.5	6	3.6
							43	-	-	7.5	241.3	222.3	33	8.5	8	3.5
							43	81	38	8	263.5	244.5	8	10.5	6	3.7
							43	73	30	10	314.3	295.3	8	10.5	8	4.2
265	2517	16	60	263	45	3	42	81	41	8	263.5	244.5	38	10.5	6	5.9
							73	73	31	10	314.3	295.3	10	10.5	8	6.2
							58.6	58.6	16	11.5	352.4	333.4	10	10.5	8	6.5
290	2517	16	60	290	4) 64	6	58	73	14	10	314.3	295.3	16	10.5	8	8.5
							58.6	58.6	0	11.5	352.4	333.4	16	10.5	8	8.8
320	3030	35	75	318	76	8	68	106.6	39	11.5	352.4	333.4	16	10.5	8	14
							92.4	92.4	25	14	466.7	438.2	16	13	8	17
360	3535	35	90	358	89	13	76	106.6	30	11.5	352.4	333.4	65	10.5	8	21
							92.4	92.4	17	14	466.7	438.2	15	13	8	24
420	4040	40	100	420	102	10	92	92.4	0	14	466.7	438.2	18	13	8	37
							82.7	82.7	0	16	517.5	489	18	13	8	38
							82.7	82.7	0	18	571.5	542.9	18	17	6	41
465	4545	55	110	465	115	28	87	92.4	5	14	466.7	438.2	85	13	8	63
							82.7	82.7	0	16	517.5	489	27	13	8	64
							82.7	82.7	0	18	571.5	542.9	18	17	6	68

1) Permissible deviation (see item 3.9).

2) Mounting dimensions for motors and generators to standard "DIN 6281" (see items 3.6 and 3.9).

3) Weights are valid for maximum bores.

4) Length of the TAPER clamping bush TB 2517 = 45 mm

TAPER clamping bushes with keyway to standard "DIN 6885 sheet 1" (hub-keyway width tolerance JS9)																			
Bush number	Bores D of the clamping bushes in mm																		
2012	14	16	18	19	20	22	24	25	28	30	32	35	38	40	42	45	48	50	60
	2517	16	18	19	20	22	24	25	28	30	32	35	38	40	42	45	48	50	55
3030	35	38	40	42	45	48	50	55	60	65	70	75							
	3535	35	38	40	42	45	48	50	55	60	65	70	75	80	85	90			
4040	40	42	45	48	50	55	60	65	70	75	80	85	90	95	100				
	4545	55	60	65	70	75	80	85	90	95	100	105	110						

2. Notes

2.1 Safety instructions and general notes



All persons involved in the installation, operation, maintenance and repair of the coupling or clutch must have read and understood these instructions and must comply with them at all times. Disregarding these instructions may cause damage to the product and material and/or injury to persons. Damage caused by disregard of these instructions will result in exclusion of liability.

During transport, installation, dismantling, operation and maintenance of the unit, the relevant safety and environmental regulations must be complied.



Lifting gears and load equipment for handling the components must be suitable for the weight of the coupling.

The coupling must be stored in a dry environment. Adequate preservation must be ensured.

Operators and users must not make any changes to the coupling themselves over and above the treatment specified in these instructions.



If there is any visible damage the coupling must not be fitted and not be put into operation.

The coupling must not be operated unless housed in a suitable enclosure in accordance with the standards applying. This also applies to test runs and when checking the direction of rotation.

All work on the coupling must be carried out only when it is at a standstill. Secure the drive unit to prevent unintentional switch-on! A notice should be attached to the ON switch stating clearly that work on the coupling is in progress.

In addition to any generally prescribed personal safety equipment (such as safety shoes, safety clothing, helmet) wear **suitable safety gloves** and **suitable safety glasses** when handling the coupling!

Dispose of coupling in accordance with national regulations or separate them for recycling.

Only spare parts made by the manufacturer Siemens must be used.



Any enquiries should be addressed to:

Siemens AG
Schlavenhorst 100
46395 Bocholt

Tel.: +49 (0)2871 / 92-0
Fax: +49 (0)2871 / 92-2596

2.2 Marking of the coupling parts for use in potentially explosive zones

Couplings which are ordered in Atex configuration, have the following marking on the outer circumference of coupling part 3:

Siemens AG	CE		II 2G T3 D160 °C X
46395 Bocholt - Germany	CE		II 2G T4 D120 °C X
FLENDER couplings ELPEX-S <year built>			-40 °C ≤ T _A ≤ 80 °C

Coupling part 2 or coupling part 1 bear the marking ].

If, in addition to the CE mark, the letter "U" together with the Siemens order number has been stamped on, the coupling part has been delivered by Siemens un- or prebored.



Siemens supplies unbored and prebored couplings with CE marking only under the condition that the customer assumes the responsibility and liability for correct refinishing in a declaration of exemption.

2.3 Operating conditions in potentially explosive areas



The machines connected by the coupling must be earthed by an earth leakage resistance <math>< 10^6 \Omega</math>.

If coated couplings are used in potentially explosive areas, the requirements made of the conductivity of the coating and the limitation on the thickness of the coat applied must be observed in accordance with standard "EN 13463-1". Where coatings have a thickness <math>< 200 \mu\text{m}</math>, no electrostatic charge is to be expected.

If they are to be used below ground in potentially explosive areas the drive motor must be switched off on occurring of an explosible atmosphere.

The type EST ELPEX-S coupling with TAPER clamping bush must not be used in potentially explosive areas.

The coupling is suited for service conditions in accordance with Directive 94/9/EC:

- **Equipment group I (underground applications, mining)**
 - Category M2 (coupling is **not approved** for equipment category M1).
- **Equipment category II (use above ground, industry)**
 - Categories 2 and 3 (coupling is **not approved** for equipment category 1).
 - Material group G (areas, in which there are explosible gas, vapour, mist, air mixtures), zones 1 and 2 (coupling is **not approved** for use in zone 0).
 - Materials group D (areas where dust can form explosible atmospheres), Zones 21 and 22 (coupling is **not approved** for equipment category 20).
 - Explosion group IIC (Explosion groups IIA and IIB are included in IIC).

- The permissible temperature classes and/or maximum surface temperatures are assigned as a function of the maximum ambient temperature occurring in the immediate vicinity of the coupling (see table 8, or for dust table 9).

Table 8: Temperature classes

Temperature class	maximum surface temperature 1)	Ambient temperature 2)	Fatigue torque 3)
T3, T2, T1	200 °C	max. 80 °C	$T_{KW \text{ perm.}} = 0.5 \times T_{KW \text{ indication in catalogue}}$
T4	135 °C	max. 80 °C	$T_{KW \text{ perm.}} = 0.3 \times T_{KW \text{ indication in catalogue}}$

Table 9: Limit temperatures for dusts

maximum surface temperature 1)	Ambient temperature 2)	Fatigue torque 3)
160 °C	max. 80 °C	$T_{KW \text{ perm.}} = 0.5 \times T_{KW \text{ indication in catalogue}}$
120 °C	max. 80 °C	$T_{KW \text{ perm.}} = 0.3 \times T_{KW \text{ indication in catalogue}}$

- 1) The maximum surface temperature depends on the ignition temperature of the combustible material in the potentially explosive environment.
- 2) Since the coupling is heating up during operation, the ambient temperature must be below the maximum surface temperature.



The ambient temperature is limited by the temperature range of the rubber elements. Observe the temperature range of the rubber elements shown in table 1.

- 3) For use in potentially explosive environments reduced fatigue torques must be adhered to. To determine the fatigue torque load, a torsional vibration calculation, for which the manufacturer of the subassemblies is responsible, may be necessary.

3. Fitting

3.1 Machining the finished bore

Depreserve and clean coupling parts (1; 2).

Clamp on surfaces marked with , and align.

Machine the finished bore. Observe the maximum dimension of the bore specified in section 1, "Technical data".

Check finished bore as described in section 7.

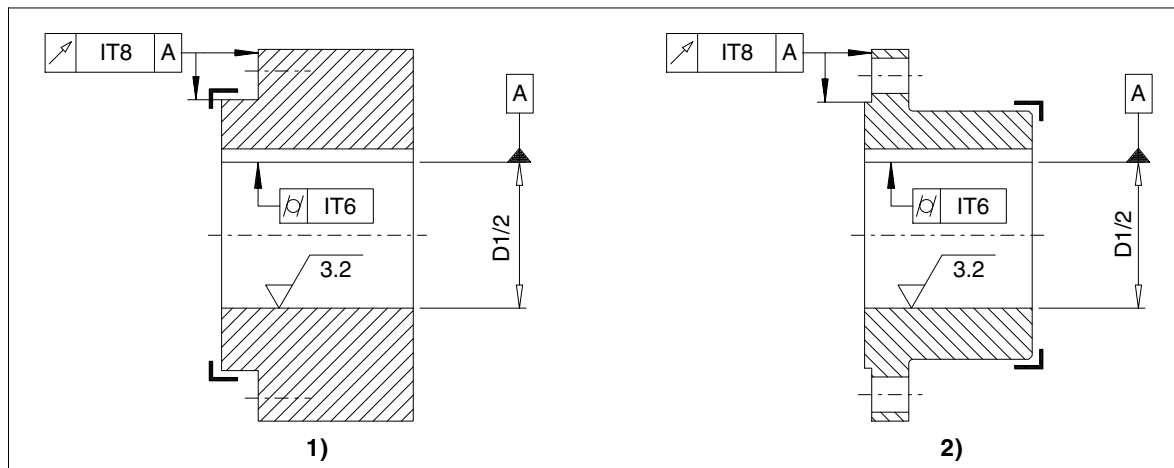

Fig. 7: Machining the finished bore

1) Types ESN, ESD

2) Types ESNR, ESDR, ESNW, ESDW

Table 10: Fit recommendation for bores with parallel-key connection

Description	Push fit not suitable for reversing operation		Press fit		Interference fit suitable for reversing operation		
	j6	h6	h6	k6	m6	n6	h6
Shaft tolerance	j6	h6	h6	k6	m6	n6	h6
Bore tolerance	H7	J7	K7	H7	H7	H7	M7

The fit assignment m6 / H7 is particularly suitable for many applications.



**Failure to observe these instructions may result in breakage of the coupling.
Danger to life from flying fragments.
The coupling then becomes an explosion hazard.**

3.2 Machining the parallel keyway

- Parallel keyway to standard "DIN 6885-1; **ISO JS9**" with usual operating conditions.
- Width of parallel keyway **ISO P9** with reversing operation.

3.3 Axial securing

Arrange set screw on the parallel keyway.

Adhere to the distance dimension "e" with $e \approx 0.3 \times NL$.

Use threaded studs to standard "DIN 916" with cup points as set screws (set-screw size to table 11).

The set screw should fill out the screw thread as much as possible and must not project beyond the hub.

Alternatively use an end plate. For the dimension of the recess, consult Siemens.

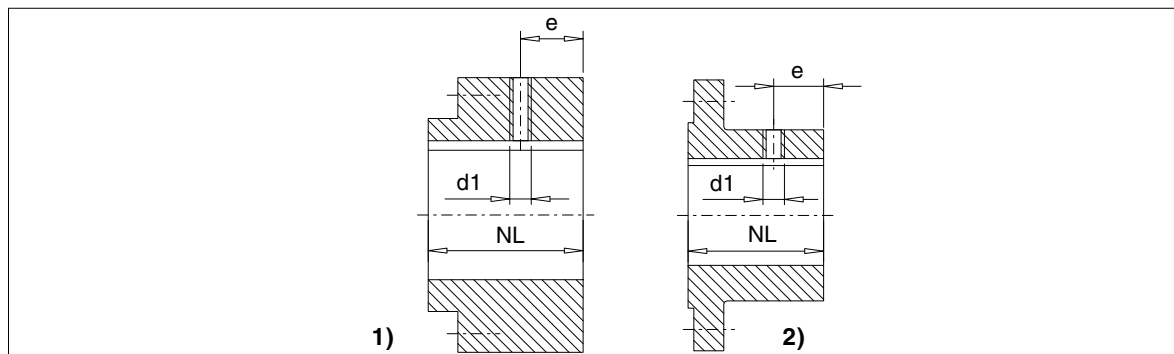

Fig. 8: Position of the set screw

1) Types ESN, ESD

2) Types ESNR, ESDR, ESNW, ESDW

Table 11: Set-screw assignment and tightening torques

Bore D		Set screw d1 mm	Tightening torque T_A Nm	Wrench width SW Hexagon socket mm
over mm	up to mm			
8	30	M 6	4	3
30	38	M 8	8	4
38	65	M 10	15	5
65	95	M 12	25	6
95	110	M 16	70	8
110	150	M 20	130	10
150	230	M 24	230	12
230	260	M 30	470	14

Tightening torques apply to bolts with untreated surfaces which are not or only lightly oiled (coefficient of friction $\mu = 0.14$). The use of lubricant paint or lubricant, which affects the coefficient of friction " μ ", is not permitted.

The specified tightening torques " T_A " must be complied with, applying standard "DIN 25202", Screw-Connection Class "C", with an output-torque scatter of $\pm 5\%$.

3.4 Balancing after machining the finished bore

The balancing quality is to be specified in accordance with the specific application (however at least G16 to standard "DIN ISO 1940").

Observe balancing prescription to standard "DIN ISO 8821" of the shaft.



Balancing bores must not affect the load-bearing capacity of the coupling parts.

Apply the balancing bores on a large radius with sufficient distance to the bores and the outer circumference.

3.5 Fitting the coupling parts 1 and 2

Unscrew the set screw.

Clean the holes and shaft ends.

Coat the bores of the coupling parts (1; 2) and the shafts with MoS₂ mounting paste (e.g. Microgleit LP 405).



Coupling parts (1; 2) with tapered bore and parallel-key connection must be fitted in cold condition and secured with suitable end disks, without drawing the coupling parts (1; 2) further onto the taper (fitting dimension = 0).

Heat coupling part (1; 2) with cylindrical bore up to maximum 150 °C, if necessary. When heating up observe the temperature range of the rubber disk elements (5; 6) (see table 1); if necessary demount the rubber disk elements (5; 6).



Heated coupling parts form an explosion hazard, therefore there must not be an explosible atmosphere when fitting the coupling parts.

Axial securing is effected by means of the set screw or end plate. When securing by set screw the shaft must not project or be set back from the inner sides of the hub.

Fit the set screw or end disk (for tightening torque of the set screw see table 11).



Failure to observe these instructions may result in breakage of the coupling. Danger to life from flying fragments. The coupling then becomes an explosion hazard.

Screw the rubber disk element (5) or the rubber disk elements (5; 6) to the hub (2) as shown in the diagrams in section 1, "Technica data". Observe the tightening torques specified in item 3.11.3.

Screw the flanged ring (101) on types ESNW and ESDW to the hub (1) as shown in the diagrams in section 1, "Technical data". Observe the tightening torques specified in item 3.11.3.

3.6 Fitting the coupling parts 5 with TAPER clamping bush on type EST

Clean the TAPER clamping bushes, holes and shaft ends.

TAPER clamping bushes have have, up to size 3030 two, and from size 3535 up, three axially parallel, cylindrical and smooth blind holes in the large end face, only half of which are however in the material of the bush. The other half, which is in the hub, have threads.

Insert rubber disk element (5) and the TAPER clamping bush one inside the other, align holes and slightly the bolts of the clamping bush.

Place the rubber disk element (5) with the TAPER clamping bush on the shaft. Note instructions in item 3.9. For dimensions of motor and generator connection to standard "DIN 6281" observe the distance dimensions "LX" and "T" and the coupling dimension "LG" during the fitting work (see items 1.7 and 3.9).

Tighten the clamping-bush screws one after the other (for tightening torques see item 3.11.4).

During the screwing-on operation the hub is drawn onto the tapered TAPER clamping bush and the bush thus pressed onto the shaft.

Fill the unused holes in the TAPER clamping bushes with grease to prevent the penetration of dirt.

3.7 Fitting the coupling

Screw the outer flange (3) to the machine to be coupled or to the flanged ring (101). Observe the tightening torques specified in item 3.11.1 or item 3.11.2. Fit the outer flange (3) and the rubber disk elements (5; 6) together.

Align the coupling as described in item 3.9.



The shaft misalignment should be kept as low as possible in order to minimize wear and restorative forces.

3.8 Possible misalignments

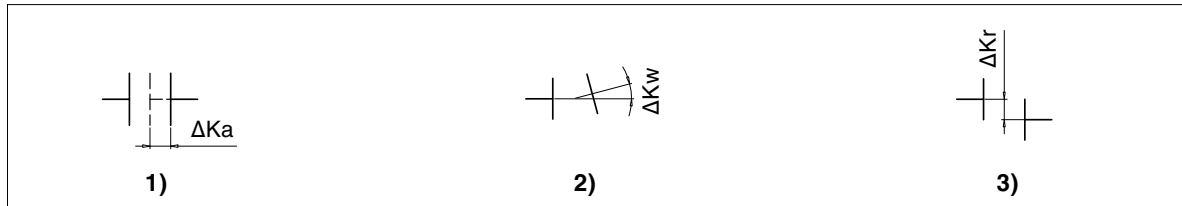

Fig. 9: Possible misalignments

- 1) Axial misalignment (ΔK_a)
- 2) Angular misalignment (ΔK_w)
- 3) Radial misalignment (ΔK_r)

3.8.1 Axial misalignment

The gap dimension ΔK_a should be set within the deviation permitted for the dimensions "S" / "LG" / "A" (see item 3.9).

3.8.2 Angular misalignment

The permissible angular misalignment $\Delta K_{w_{perm}}$ can be found in table 13 (depending on the operating speed).

3.8.3 Radial misalignment

The permissible radial misalignment $\Delta K_{r_{perm}}$ can be found in table 13 (depending on the operating speed).

3.9 Alignment



When aligning, the angular and radial misalignment should be kept as low as possible.

Misalignment values specified in table 13 are maximum permissible overall values in operation, resulting from mispositioning through imprecision during alignment and misalignment through operation (e.g. deformation through load, heat expansion).

Reduced misalignment in the coupling minimises expected wear on the rubber disk elements. Misalignment in the coupling gives rise to restorative forces which may impose inadmissible stress on adjacent machine parts (e.g. bearings).

Alignment in case of flanged couplings must be done from the coupling half on the shaft side to one of the machined surfaces of the motor flywheel or motor housing.

In case of shaft couplings the angular and radial misalignment between the two coupling halves is determined in the usual way by passing a dial gauge over them.

Table 12: Distance dimensions

Size	Fitting
	Distance dimensions A, S, LG, T, LX ΔS mm
220	1.3
265	1.3
290	1.5
320	1.5
360	1.5
420	1.5
465	1.7
520	1.7
560	1.7
580	1.8
680	1.8
770	2.0

When fitting the distance dimensions must be kept within the following limits:

$$A_{\min.} = A - \Delta S$$

$$A_{\max.} = A + \Delta S$$

$$S_{\min.} = S - \Delta S$$

$$S_{\max.} = S + \Delta S$$

$$LG_{\min.} = LG - \Delta S$$

$$LG_{\max.} = LG + \Delta S$$

$$T_{\min.} = T - \Delta S$$

$$T_{\max.} = T + \Delta S$$

$$LX_{\min.} = LX - \Delta S$$

$$LX_{\max.} = LX + \Delta S$$

3.10 Shaft-misalignment values during operation



The following maximum permissible misalignment values must by no means be exceeded during operation.
When aligning, the angular and radial misalignment should be kept as low as possible.

Table 13: Shaft-misalignment values $\Delta K_{a,perm.}$, $\Delta K_{r,perm.}$ and $\Delta K_{w,perm.}$, maximum permissible during operation, stated in mm (rounded)

Size	Permissible shaft-misalignment values ΔK_{1500} at $n = 1500$ 1/min	
	Radial ΔK_r mm	Angular ΔK_w Degree
220	1.2	0.5
265	1.2	0.5
290	1.2	0.5
320	1.2	0.5
360	1.2	0.5
420	1.3	0.4
465	1.3	0.4
520	1.4	0.4
560	1.4	0.4
580	1.5	0.3
680	1.5	0.3
770	1.5	0.3

Permissible shaft misalignment:

The permissible shaft misalignment depends on the operating speed. With increasing speeds only lower shaft-misalignments values are permissible. Table 14 shows the correction factors for the various speeds. Observe the maximum speed of each coupling size and coupling type!

$$\Delta K_{perm.} = \Delta K_{1500} \times FKV$$

Table 14: Correction factor

	Speed in 1/min			
	500	1000	1500	3000
Correction factor FKV	1.20	1.10	1.0	0.70

3.11 Bolt-tightening torques



The use of impact screwdrivers is not permissible!

Tightening torques apply to bolts with untreated surfaces which are not or only lightly oiled (coefficient of friction $\mu = 0.14$). The use of lubricant paint or lubricant, which affects the coefficient of friction " μ ", is not permitted.

The specified tightening torques " T_A " must be complied with, applying standard "DIN 25202", screw-connection class "C", with an output-torque scatter of $\pm 5\%$.

The tightening torques and wrench widths of the set screws are specified in table 11.

3.11.1 Bolt-tightening torques for bolting the outer flange (3) to the motor flywheel

Table 15: Tightening torques for screw connection of coupling part 3 to motor flywheel

Size of flywheel to SAE J620d	6 1/2	7 1/2	8	10	11 1/2	14	16	18	21	24	-
Flange connection D_1 in mm	215.9	241.3	263.5	314.3	352.4	466.7	517.5	571.5	673.5	733.5	860, 920, 995
Bolt size	M 8		M 10			M 12		M 16		M 20	
Tightening torque T_A in Nm	25		49			86		210		420	
Inch bolts	5/16 - 18		3/8 - 16			1/2 - 13		5/8 - 11		3/4 - 10	
Tightening torque T_A in Nm	24		42			102		203		340	

Bolts of strength class 8.8 must be used, if possible with a shim to standard "DIN 125".

3.11.2 Bolt-tightening torques for bolting the outer flange (3) to the flanged ring (101) of types ESNW, ESDW

Table 16: Tightening torques for coupling part 31

Coupling size	265, 290, 320, 360	420, 465	520, 560, 580, 680	770
Wrench width SW for hexagon head	17	19	24	30
Tightening torque T_A in Nm	49	86	210	420

Bolts of strength class 8.8 must be used, if possible with a shim to standard "DIN 125".

3.11.3 Bolt-tightening torques for bolting the hub (2) to the rubber disk element (5; 6) and the hub (1) to the flanged ring (101)

Table 17: Tightening torques for coupling part 25 and coupling part 125

Coupling size	220	265	290 320	360 420	465		520		560		580, 680, 770		ESDR 770
Wrench width SW for hexagon head	13	19	19	24	24	30	24	30	24	30	30	36	36
Tightening torque T_A in Nm	35	86	86	210	210	420	210	420	210	420	420	710	1000
Strength class	10.9	8.8	8.8	8.8	8.8	8.8	8.8	8.8	8.8	8.8	8.8	8.8	10.9

3.11.4 TAPER clamping bushes

Table 18: Assignment of tightening torques and wrench widths

TAPER clamping bush No.	Tightening torque T_A and wrench width SW for fastening screws with hexagon socket			
	BSW Inch	Length Inch	T_A Nm	SW mm
2012	7/16	7/8	31	5
2517	1/2	1	48	6
3030	5/8	1 1/4	90	8
3535	1/2	1 1/2	113	10
4040	5/8	1 3/4	170	12
4545	3/4	2	192	14

4. Start-up and operation



Check bolt-tightening torques for the coupling and tightening torques for the foundation bolts of the coupled machine before start-up. Enclosures (coupling protection, contact prevention at least IP2X) must be fitted. Overload conditions during start-up cannot be excluded. If the coupling breaks through overload, metal parts may fly off and cause personal injury and/or material damage.



If it is to be used below ground in potentially explosive areas, the coupling, which is made of cast iron or steel, must be provided with a robust casing to preclude the risk of ignition from e.g. friction, impact or friction sparks. The depositing of heavy-metal oxides (such as rust) on the coupling must be precluded by the casing or other suitable precautions.

The coupling must run with little noise and without vibration. Irregular behaviour must be treated as a fault requiring immediate remedy. In case of fault the drive must be stopped at once. The necessary measures for repair must be taken in accordance with the safety regulations applying.

5. Faults, causes and remedy

Table 19: Faults, dangers and measures

Faults	Dangers	Measures
Changes in running noise; vibrations	Flying fragments Danger of ignition through sparking	Trouble-shooting in accordance with item 5.1 and item 5.2 and remedy the cause. Check all parts of the coupling for any damage.
Premature wear of the rubber elements; alteration in the characteristics of the rubber	Damage to the coupling Failure of the installation	Replace damaged parts. For re-assembly, the instructions in sections 3 and 4 must be observed.

5.1 Possible cause of the fault

Change in alignment:

- Rectify the cause of the change in alignment (e.g. loose foundation bolts).
- Align the coupling.
- Check axial alignment; adjust as necessary.

Damages/cracks in the rubber disk element:

- Check the rubber disk elements as described in section 6, "Maintenance and repair"; if necessary, replace the rubber disk elements.

5.2 Incorrect use



Failure to observe these instructions may result in breakage of the coupling. Danger to life from flying fragments. The coupling then becomes an explosion hazard.

5.2.1 Frequent faults when selecting the coupling and/or coupling size

- Important information for describing the drive and the environment are not communicated.
- System torque too high.
- System speed too high.
- Application factor not correctly selected.
- Chemically aggressive environment is not taken into consideration.
- The ambient temperature is not permissible.
- Finished bore with inadmissible diameter and/or inadmissible assigned fits.
- Machining of parallel keyways of which the width across corners is greater than the width across corners of the parallel keyways to standard "DIN 6885/1" with a maximum permissible bore.
- The transmission capacity of the shaft-hub connection is not appropriate to the operating conditions.
- Maximum load or overload conditions are not being taken into consideration.
- Dynamic load conditions are not being taken into consideration.
- Shaft-hub connection resulting in impermissible material stress on the coupling.
- Operating conditions are being changed without authorisation.
- Coupling and machine or drive train form a critical torsional, axial or bending vibration system.
- Fatigue torque load too high.

5.2.2 Frequent faults when fitting the coupling

- Components with transport or other damage are being fitted.
- When fitting coupling parts in a heated condition, already fitted rubber elements are being excessively heated.
- The shaft diameter is beyond the specified tolerance range.
- Coupling parts are being interchanged, i.e. their assignment to the specified shaft is incorrect.
- Specified axial securing means are not fitted.
- Specified tightening torques are not being adhered to.
- Bolts are inserted dry or greased.
- Flange surfaces of screwed connections have not been cleaned.
- Alignment and/or shaft-misalignment values do not match the specifications in the instructions manual.
- The coupled machines are not correctly fastened to the foundation, and as a result shifting of the machines e.g. through loosening of the foundation-screw connection is causing excessive displacement of the coupling parts.
- The coupled machines are not sufficiently earthed.
- ELPEX-S rubber disk element is not correctly positioned.
- The coupling guard used is not suitable.

5.2.3 Frequent faults in maintenance

- Maintenance intervals are not being adhered to.
- No genuine ELPEX-S spare parts are being used.
- Old or damaged ELPEX-S spare parts are being used.
- Leakage in the vicinity of the coupling is not being identified and as a result chemically aggressive media are damaging the coupling.
- Fault indications (noise, vibrations, etc.) are not being observed.
- Specified tightening torques are not being adhered to.
- Alignment and/or shaft-misalignment values do not match the specifications in the instructions manual.

6. Maintenance and repair

6.1 General

Inspections are limited to a visual assessment of the condition of the coupling. Doing so check for tightness of the screws and any damage caused by force. In all cases inspection of the coupling should be carried out simultaneously with inspection of the whole system. Doing so the rubber disk elements must be visually inspected. Dismounting is not necessary to this purpose.

6.2 Replacement of wearing parts

Replace rubber disk elements as soon as cracks of a length exceeding 20 mm or a depth exceeding 5 mm appear on the surface.



If the above specified maintenance instructions are not adhered to, a correct operation within the meaning of the explosion-prevention requirements and/or Directive 94/9/EC can no longer be guaranteed. Use in potentially explosive areas is then not permitted.



Failure to observe these instructions may result in breakage of the coupling. Danger to life from flying fragments.

On types ESNR and ESDR couplings the rubber disk elements can be demounted in radial direction. On all other types the coupled machines must be shifted. If required, loosen the outer flange (3) and pull it back. Undo the screw connection (25) and remove the rubber disk elements (5; 6). Demounting the rubber disk elements (5) type EST as described in item 6.4.

For re-assembly, the instructions in sections 3, "Fitting", and 4, "Start-up and operation", must be observed.

6.3 Demounting the coupling parts 1 and 2 in case of shaft-hub connection with parallel key

Move the coupled machines apart.

Remove the axial securing means (set screw, end plate). Mount a suitable detaching device. Using a burner, heat coupling part (1; 2) along its length and above the parallel keyway (max. + 80 °C). When heating up observe the temperature range of the rubber disk elements (5; 6) (see table 1); if necessary demount the rubber disk elements (5; 6).



Burner an heated coupling parts form an explosion hazard, therefore there must not be an explosible atmosphere when fitting the coupling parts.

Pull off coupling part (1; 2). Examine the hub bore and the shaft for damage, and protect against rust. Replace damaged parts.

For re-assembly, the instructions in sections 3, "Fitting", and 4, "Start-up and operation", must be observed.

6.4 Demounting the coupling parts 5 with TAPER clamping bush on type EST

Move the coupled machines apart.

The TAPER clamping bushes are released by removing the bolts. One of the bolts is then screwed into the bush thread as a forcing-off screw and tightened.

From TAPER clamping bush no. 3535 onwards, two forcing-off screws are provided.

The coupling part thus released can be pulled off by hand with the TAPER clamping bush without tools. Examine the coupling parts 5, the TAPER clamping bush and the shaft for damage and protect against rust. Replace damaged parts.

For re-assembly, the instructions in sections 3, "Fitting", and 4, "Start-up and operation", must be observed.

7. Stocking spare parts

7.1 Spare parts

For ordering spare parts state the following data, as far as possible:

- Siemens order number and position
- Siemens drawing number
- Coupling type and coupling size
- Type of rubber disk element (WN, NN, SN or NX)
- Part number (see spare-parts list)
- Bore, bore tolerance, keyway and balancing as well as particular characteristics such as flange-connection dimensions, spacer length, brake-drum dimensions.
- Any special details such as temperature, electrically insulating.

Table 20: Spare-parts list

Part number	Designation	ESN	ESNR	EST	ESD	ESDR	ESNW	ESDW
1	Coupling part 1 ¹⁾						x	x
2	Coupling part 2	x	x		x	x	x	x
3	Coupling part 3	x	x	x	x	x	x	x
5	Rubber disk element	x		x	x	x		x
6	Rubber disk element		x			x	x	x
25	Bolt	x	x		x	x	x	x
31	Bolt						x	x
101	Flange ¹⁾						x	x
105	TAPER clamping bush			x				
125	Bolt ¹⁾						x	x

¹⁾ Depending on the size, coupling part 1 is also constructed in two parts (1; 101) with a screw connection (125).

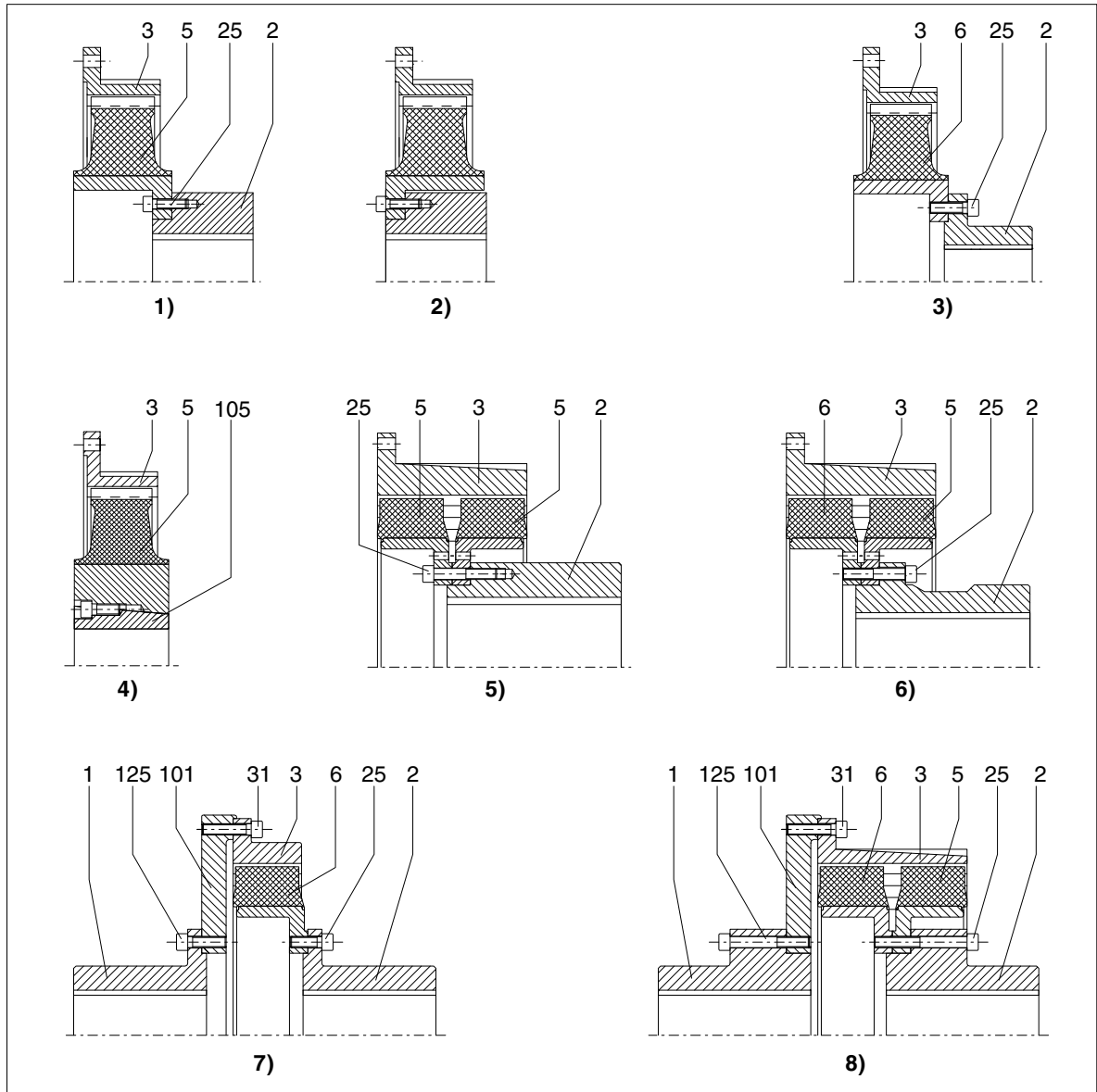

Fig. 10: Spare-parts drawing

- 1) Type ESN, long version
- 2) Type ESN, short version
- 3) Type ESNR
- 4) Type EST
- 5) Type ESD
- 6) Type ESDR
- 7) Type ESNW
- 8) Type ESDW

8. Declarations

8.1 EC declaration of conformity



EC declaration of conformity

within the meaning of EC Directive 94/9/EC of 23.03.1994 and the legal requirements laid down for its implementation

The manufacturer, Siemens AG, 46395 Bocholt, Germany, declares that the equipment described in these assembly and operating instructions:

FLENDER ELPEX-S® couplings Types ESD, ESDR, ESN, ESNR, ESNW, ESDW, EST

is in conformity with Article 1 and Article 8, Paragraph 1 b) ii) of Directive 94/9/EC and complies with the requirements of Directive 94/9/EC and the following standards:

DIN EN 1127-1 : 10-2011
DIN EN 13463-1 : 07-2009
DIN EN 13463-5 : 10-2011

The technical documentation has been delivered to the body named below:

DEKRA EXAM GmbH, 44727 Bochum, Germany, code number: 0158

Bocholt, 2012-06-26

Andre Jansen
(Director Engineering KUE)

A handwritten signature in black ink, appearing to read 'Jansen', written over a horizontal line.

Bocholt, 2012-06-26

Nicola Warning
(Director Business Subsegment KU)

A handwritten signature in black ink, appearing to read 'N. Warning', written over a horizontal line.

Further Information:

"FLENDER gear units" on the Internet

www.siemens.com/gearunits

"FLENDER couplings" on the Internet

www.siemens.com/couplings

Service & Support:

<http://support.automation.siemens.com/WW/view/en/10803928/133300>

Lubricants:

<http://support.automation.siemens.com/WW/view/en/42961591/133000>

Siemens AG
Industry Sector
Mechanical Drives
Alfred-Flender-Straße 77
46395 Bocholt
GERMANY

Subject to modifications

© Siemens AG 2012

www.siemens.com/drive-technologies